



High speed switching diodes

MMDL914

FEATURES

- Small Surface Mounting Type:
SOD-323
- High Speed :t=4.0ns Typ



Lead-free

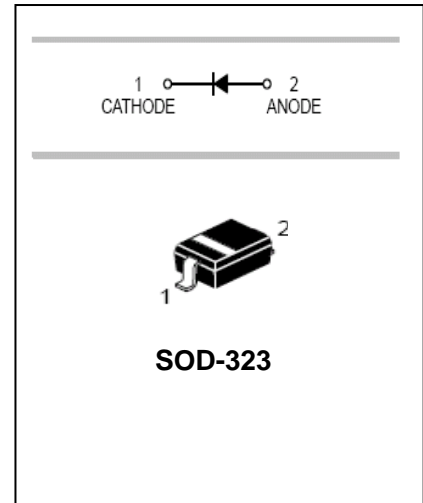

APPLICATIONS

- High speed switching

ORDERING INFORMATION

Type No.	Marking	Package Code
MMDL914	5D	SOD-323

MAXIMUM RATING @ Ta=25°C unless otherwise specified

Parameter	Symbol	Limits	Unit
Reverse Voltage	V_R	100	V
Forward Current	I_F	200	mA
Peak forward surge current	$I_{FM(surge)}$	500	mA
Power Dissipation	P_D	200	mW
Thermal resistance junction to ambient	$R_{\theta JA}$	635	°C/W
Junction temperature	T_j	150	°C
Storage temperature	T_{STG}	-55 to +150	°C

ELECTRICAL CHARACTERISTICS @ Ta=25°C unless otherwise specified

Parameter	Symbol	Min.	Typ.	Max.	Unit	Conditions
Reverse breakdown voltage	$V_{(BR)}$	100			V	$I_R=100\mu A$
Forward voltage	V_F			1.0	V	$I_F=10mA$
Reverse current	I_R			25 5.0	nA μA	$V_R=20V$ $V_R=75V$
Capacitance between terminals	C_T			4.0	pF	$V_R=0V, f=1.0MHz$
Reverse Recovery Time	t_{rr}			4	ns	$I_F=I_R=10mA$



High speed switching diodes

MMDL914

TYPICAL CHARACTERISTICS @ $T_a=25^\circ\text{C}$ unless otherwise specified

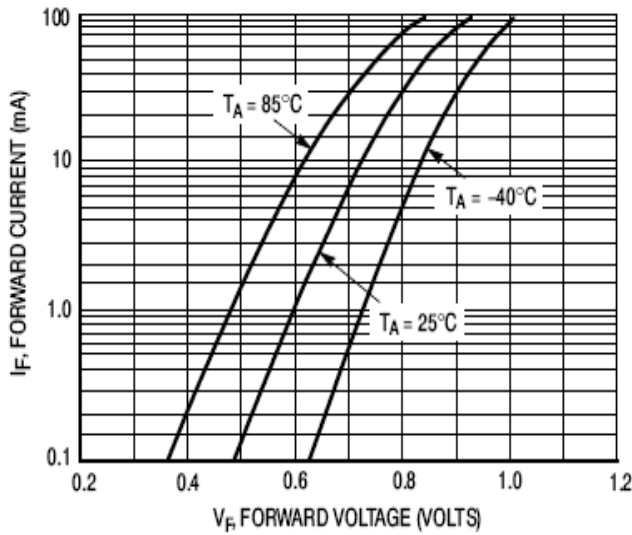

Figure 2. Forward Voltage

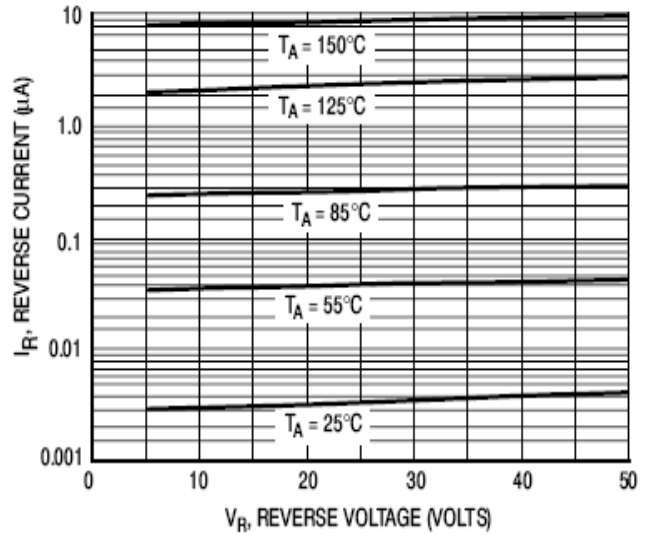

Figure 3. Leakage Current

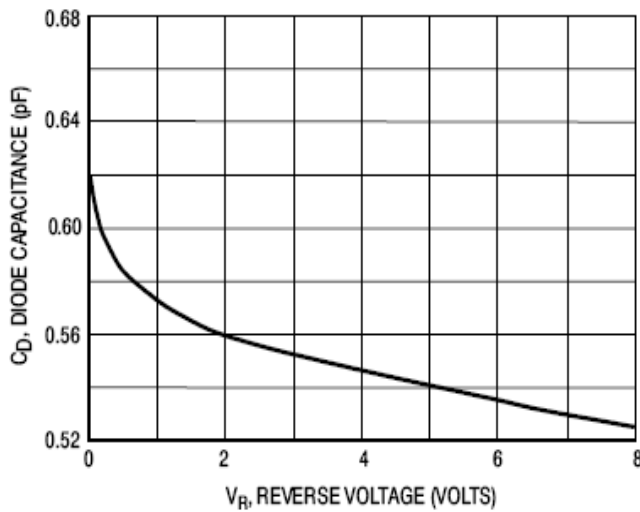

Figure 4. Capacitance

High speed switching diodes

MMDL914

PACKAGE OUTLINE

Plastic surface mounted package

SOD-323

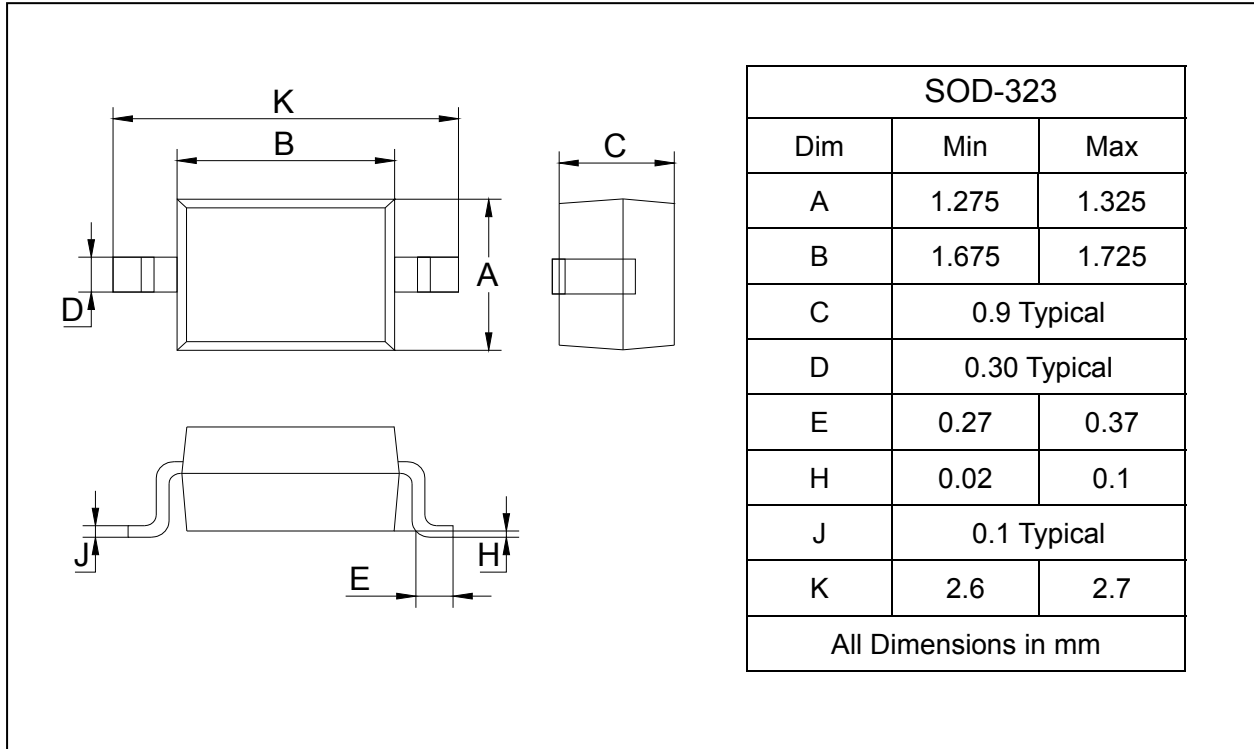

SOLDERING FOOTPRINT

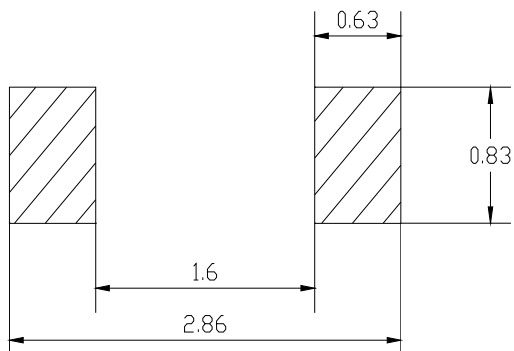

Unit : mm

PACKAGE INFORMATION

Device	Package	Shipping
MMDL914	SOD-323	3000/Tape&Reel